

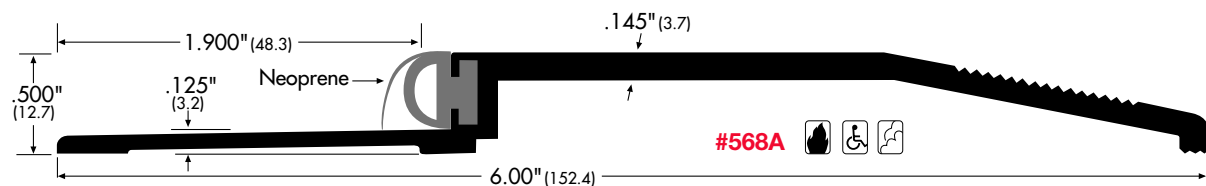

Rabbeted Saddles

Note: A = Aluminum
B = Bronze

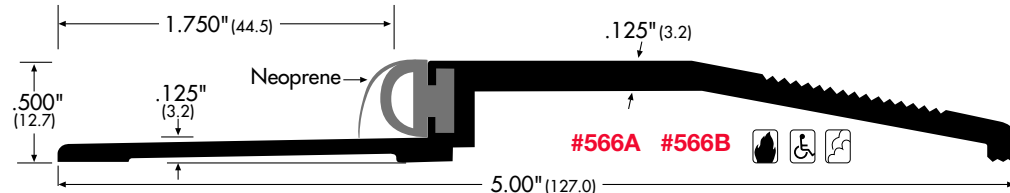
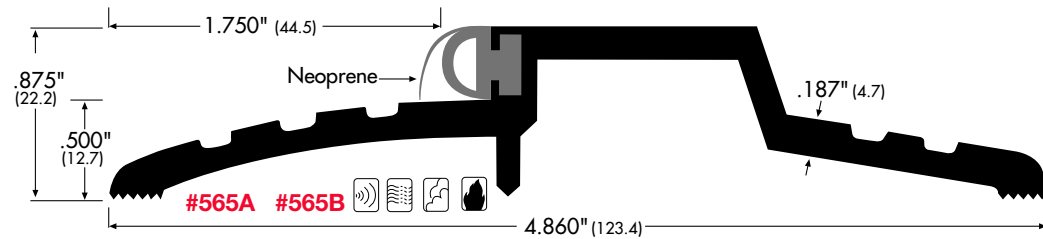
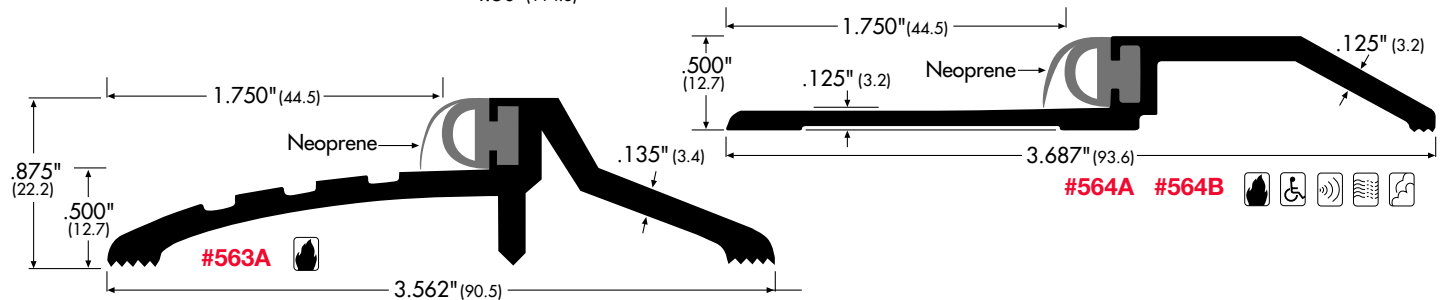
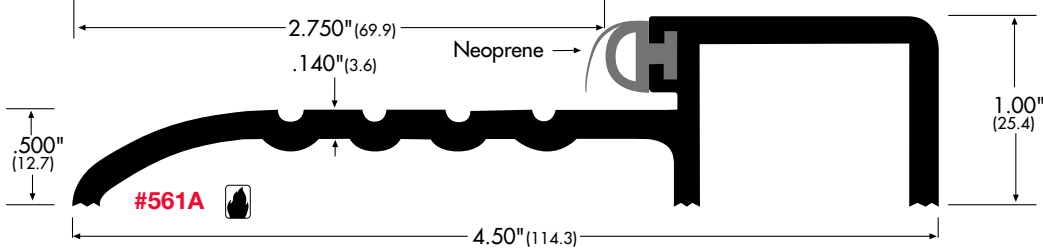
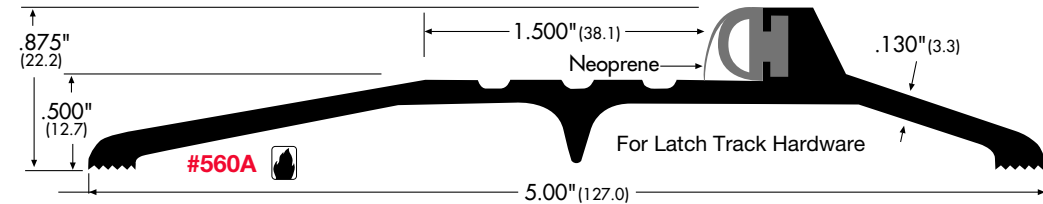
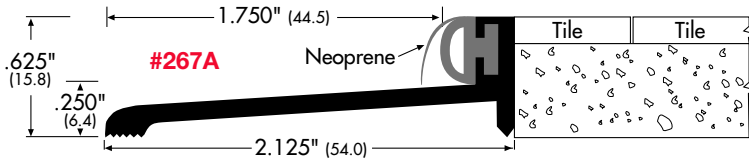
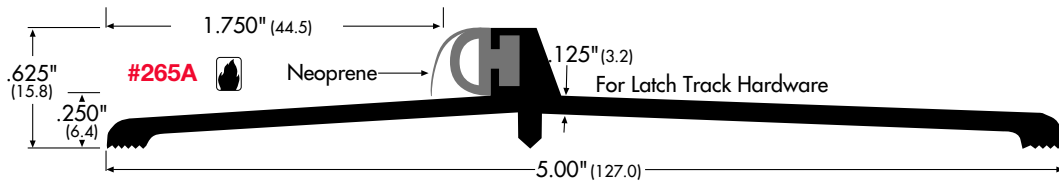
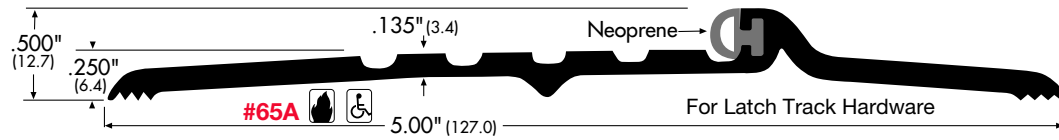

SPECIFY THIS SPECIAL FEATURE

The neoprene gasket is designed with an extra lip for double seal protection, and to compensate for any warping or misalignment during installation.

Compress-O-Matic®

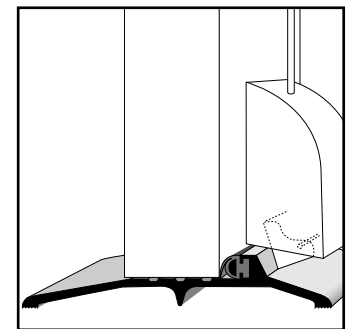

#65, 265, 560 TYPE
For Latch Track Hardware (Option)

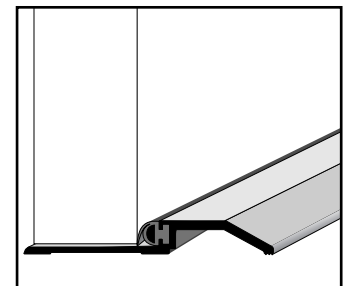

#563, 564, 565, 566 TYPE

Saddles